

# Working Clearances of Design Envelope Pump Controls

---

White paper

**File No:** 100.254  
**Date:** MARCH 11, 2021  
**Supersedes:** NEW  
**Date:** NEW

—

—

—

—

Many pumping units are installed in small mechanical rooms, with little wall space for VFD drives. Not only is wall space often unavailable, finding working space and space around VFD drives is also challenging. Installing Design Envelope pumps with integrated controls allows valuable wall real estate to be freed up.

One common question with using Design Envelope integrated controls is how to meet the required working clearance of electrical equipment as outlined by the National Electrical Code (NEC). **TABLE 110.26(A)(1)** provides the minimum required working space depth for electrical equipment rated 0-1000 volts (to ground) that is likely to be examined or worked on while energized.

**2017 NEC ARTICLE 110.26 – WORKING SPACE**

**TABLE 110.26(A)(1)**

NOMINAL VOLTAGE TO GROUND	MINIMUM CLEAR DISTANCE		
	CONDITION 1	CONDITION 2	CONDITION 3
0-150	3ft (900mm)	3ft (900mm)	3ft (900mm)
151-600	3ft (900mm)	3ft 6in (1.0m)	4ft (1.2m)
601-1000	3ft (900mm)	4ft (1.2m)	5ft (1.5m)

1. Depth of Working Space. The working space, which is measured from the enclosure front, must not be less than the distances contained in **TABLE 110.26(A)(1)**.
  - **Condition 1** - Exposed live parts on one side of the working space and no live or grounded parts on the other side of the working space, or exposed live parts on both sides of the working space that are effectively guarded by insulating materials.
  - **Condition 2** - Exposed live parts on one side of the working space and grounded parts on the other side of the working space. Concrete, brick, or tile walls shall be considered as grounded.
  - **Condition 3** - Exposed live parts on both sides of the working space
2. A 30 in. wide working space in front of equipment operating at 600V or less; and
3. Minimum headroom clearance of 6½ ft or the height of the equipment, whichever is greater.

As Armstrong’s Design Envelope controls are not **likely to be examined or worked on while energized**, the minimum clear distance requirements outlined in **TABLE 110.26(A)(1)** do not apply. This is because the pump is disconnected from the mains power supply before any work can be done on any part of the pump - e.g. an operator could not do a mechanical seal change if there was still live power to the pump.

Armstrong recommends that the working clearance in front of the controls be the minimum distance required for access to service the controls - i.e. that there be enough clearance to remove the cover, and sufficient space be provided for an operator to safely access the controller parts. See **FIGURE 1**.

**FIGURE 1: CLEARANCE FOR DESIGN ENVELOPE PUMP CONTROLS**

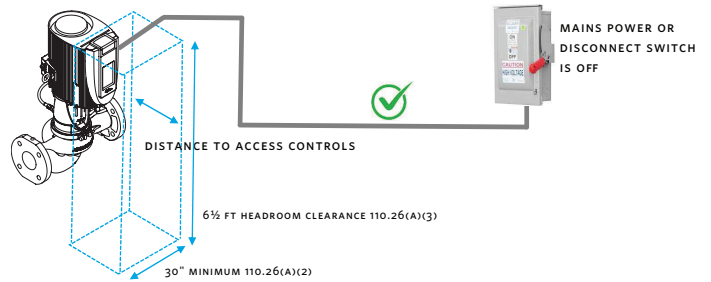

Only Armstrong Design Envelope controls with integral disconnect switches, are required to adhere to Article 110.26. Even with the integral disconnect switch set to the Off position with no power to the motor, it still allows a portion of the controller to be energized (see red area in **FIGURE 2**) and if the front cover is removed for service, now exposes live parts.

**FIGURE 2: CLEARANCE FOR DESIGN ENVELOPE PUMP CONTROLS WITH INTEGRAL DISCONNECT SWITCH**

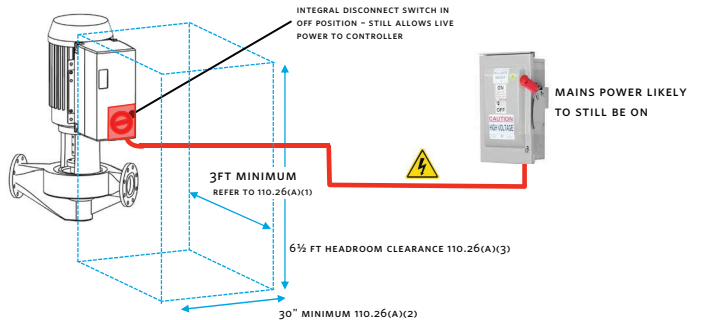

This approach also applies to Design Envelope Boosters where there is often concern about positioning the pump controllers against a wall. The pump controllers are not required to meet

4

110.26(1); sufficient distance should be provided for access to service the controls. Only the main control panel with integral disconnect switch is required to meet 110.26(A)(1) minimum 3ft clearance as live power may still be present in the red area as shown in **FIGURE 3**.

This interpretation of Article 110.26 has been reviewed and provided by members of the National Electrical Code Committee, responsible for Article 110.

**FIGURE 3: CLEARANCE FOR DESIGN ENVELOPE BOOSTERS**

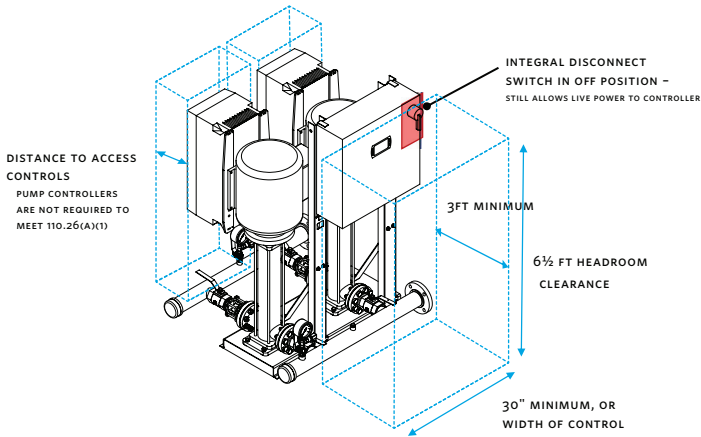

TORONTO  
+1 416 755 2291

BUFFALO  
+1 716 693 8813

DROITWICH SPA  
+44 8444 145 145

MANCHESTER  
+44 8444 145 145

BANGALORE  
+91 80 4906 3555

SHANGHAI  
+86 21 5237 0909

SÃO PAULO  
+55 11 4785 1330

LYON  
+33 4 26 83 78 74

DUBAI  
+971 4 887 6775

MANNHEIM  
+49 621 3999 9858

JIMBOLIA  
+40 256 360 030