

# The Advantages of Hydronic Systems versus Variable Refrigerant Flow (VRF) - A Critical Analysis

---

## White Paper

File No: 9.884  
Date: JUNE 29, 2020  
Supersedes: NEW  
Date: NEW

—

—

—

—

## SUMMARY

The attached white paper presents a review of technical literature and post-installation analysis of three types of HVAC systems: Variable Refrigerant Flow (VRF), hydronics, and hydronics integrated with Armstrong Design Envelope technology.

Critical analysis and comparison of these three technologies revealed:

- 1. Lifecycle operating costs of hydronic systems were significantly lower than VRF systems. Moreover, use of Design Envelope technology further reduced ownership costs for hydronic systems.**
  - On an annualized basis, hydronic systems offered energy savings of 57% to 84% compared to VRF systems installed in the same building and addressing similar loads
    - Compared to VRF, hydronic systems require half of the total electrical cooling energy required for moving BTUs
    - Actual heating COP of VRF is approximately 30% below the rated heating COP when outdoor air temperature (OAT) < 50°F
    - VRF COP decreases from rated values as total piping length increases above 25 ft
    - VRF undergoes defrost cycles and oil return cycles, which are energy-intensive modes
  - Design Envelope technology extends the savings offered by hydronic systems
    - Hydronic system energy consumption is reduced significantly — up to 80% less pumping energy used
    - Armstrong integrated solutions (Integrated Plant Control, Intelligent Fluid Management Systems and Opti-Point) further increase energy savings by up to 50% and water savings by up to 5%
    - Armstrong integrated control solutions can extend equipment life by up to 10%
    - Armstrong's cloud connectivity, combined with Active Performance Management, can offer up to a 40% reduction in lifecycle operating cost over traditional hydronics
    - Addressing installed redundancy requirements with Armstrong's Design Envelope technology can lower plant energy consumption by 15%
  - VRF is specifically designed for use with R-410A, which is a hydrofluorocarbon slated for phase-out as per the Kigali Amendment of the Montreal Protocol
  - VRF equipment has an average life of 15 years, whereas hydronic equipment averages 20–25 years
  - The entire VRF system is proprietary, and all replacement must be sourced through the manufacturer for the life of the system
- 2. Similarly, hydronic systems required a lower first installed cost commitment than VRF. Hydronic systems employing Design Envelope offered even greater savings.**
  - Traditional hydronic systems range from \$11.90/ft<sup>2</sup> to \$31/ft<sup>2</sup> for schools and apartment buildings, respectively. In contrast, VRF systems cost between \$14.90/ft<sup>2</sup> and \$34/ft<sup>2</sup> for the same installations
    - Total installed cost of chiller based hydronic systems is significantly lower than VRF systems with the same capacity
    - To minimize the potential for refrigerant-induced asphyxiation, VRF requires unique and extensive design considerations (zoning changes, refrigerant leak detection, splitting a single system into multiple systems, etc.), which directly increase installed cost
    - Using high-pressure refrigerant as a working fluid (that is distributed throughout a building) results in more stringent and costly installation requirements
    - VRF requires all building components to be connected to a single control system through daisy chains; this adds time and cost to installation and commissioning
    - VRF tenders are less competitive due to manufacturer-specific design criteria and limitations
  - VRF systems must be oversized to compensate for differences between rated and actual (installed) capacity
    - VRF de-rates at outdoor air temperatures below 50°F. Significant de-rate occurs at Outdoor Air Temperature < 10°F. Compensating for this requires additional installed capacity or ancillary heating systems
    - VRF de-rates as total system piping increases: VRF produces only 80% of total capacity for 600 ft of piping
  - VRF is ineffective at addressing multiple load types (i.e., latent loads). Applications such as domestic hot water or snow melt still require hydronic infrastructure, which increases first installed costs
  - VRF offers less flexibility with respect to piping requirements
  - During installation, if a design change is required, the design must first be reviewed and approved by VRF manufacturers. For larger systems, deviations from the original design may not be possible, despite criticality
  - Design Envelope reduces the first installed cost of hydronic systems by reducing the need for peripheral equipment, such as housekeeping pads, harmonic filters, vibration bases, sensors and redundant components
  - Armstrong's Design Envelope technology and appropriate redundancy can lower plant cost by 25%

## 1 INTRODUCTION & BACKGROUND

Hydronic systems are defined by the use of a liquid heat transfer medium typically consisting of water, glycol and/or steam. These systems are one of the oldest and most thoroughly researched and developed technologies for heating and cooling spaces: dating back to 2<sup>nd</sup> and 3<sup>rd</sup> century BC, primitive hydronic systems consisted of furnaces connected to a **series of flue passages realized under the floor by means of pillars carrying a slab and then exhausted through cavities in the walls** (Bean, 2010). Today, a large majority of HVAC systems throughout the world are based on hydronics.

In contrast, VRF, also known as variable refrigerant volume (VRV), is a relatively new technology in the North American HVAC (NA-HVAC) market, first appearing in the early 2000's. Developed in Japan during the 1980s, VRF uses refrigerant as a working fluid to connect centralized condensers with multiple evaporators (of various types and capacities) located throughout a building envelope.

In recent years, the number of manufacturers of VRF in North America has grown significantly. With this increased presence, marketing efforts to position VRF as a better alternative to traditional hydronics-based solutions have become common.

To address the claims of superiority of VRF over hydronics by manufacturers of VRF, this paper will analyze the validity and accuracy of the most common claims.

The majority of claims are centralized around the following considerations:

- Lifecycle operating cost
- First installed cost

By reviewing technical literature and post-installation analysis, this paper will correct the perception of low-cost VRF and show that hydronics-based systems are more cost-effective when applied to real-world situations.

Furthermore, this paper will show that the integration of Design Envelope technology into hydronic systems dramatically increases the cost-savings benefits.

## 2 LOWEST LIFECYCLE OPERATING COST

Manufacturers of VRF claim lifetime cost of their technology is far lower than that of hydronics-based systems. The explanation is based on the following claims:

- VRF wastes less energy
- VRF has higher rated efficiency
- VRF requires simpler and more streamlined maintenance

## 2.1 ENERGY CONSUMPTION

Manufacturers of VRF often state that energy consumption in VRF systems is far lower than that of hydronics-based systems. The logic behind this claim goes as follows:

- VRF does not require separate pumps/fans to move working fluid
- VRF condensers use at least one variable speed scroll compressor, and VRF evaporators use ECM motors for better turndown than induction motors

### 2.1.1 TRANSPORT ENERGY

Although the claim that **VRF does not require separate pumps and/or fans to move working fluid through a building** is accurate, the implications are rarely presented.

This is because **the compressor in a VRF system has a dual purpose: it compresses and raises the temperature of the fluid and also propels fluid through the building** (Alliance, 2014). So, in addition to moving refrigerant, an inherent requirement of VRF technology is the need to propel lubricant throughout the building as well.

Because of the fluid properties of lubricant, as well as the various phases of refrigerant, VRF uses higher fluid velocities within system piping. These higher velocities ensure that lubricant, which is required for proper compressor operation, is carried back to the compressor despite flow impediments such as elevation changes and sections where the refrigerant is in vapor phase. Fluid velocities in VRF systems are approximately 10 times higher than in hydronic systems (Alliance, 2014).

Unfortunately, higher fluid velocity results in a greater drop in pressure due to fluid dynamics. It is estimated that pressure drop and corresponding transport energy requirements increase proportionately with velocity for Reynolds numbers below 21,000 and proportionate to the square of velocity for Reynolds numbers above 21,000.

The greater pressure drop must be overcome by the compressor. This forces the compressor to operate at higher frequencies which consumes more energy.

In contrast, hydronics-based systems, do not have such requirements. Fluid velocities can be as low as 1.5ft/s (Swanson, 2017), which is considered the minimum velocity required to prevent deposition of dissolved solids and ensure release of entrained air through purification devices. At the other end of the spectrum, velocities in hydronic systems can climb as high as 10-12 ft/s, beyond which excessive erosion becomes a concern (depending on piping material, hours of operation, water quality, etc.).

Typically, hydronic systems operate between 4 ft/s and 6 ft/s. In this velocity range, the effects of entrained air or dissolved solids are addressed, erosion and excessive noise are avoided, and first cost is balanced with lifetime cost.

When the cumulative transport energy used in hydronics-based systems is compared to that required by VRF, it becomes evident that hydronics-based systems consume less energy in the distribution of heating and cooling loads.

The extent of this difference in energy usage can be seen in **FIGURE 1**. Hydronics-based systems consume approximately 33% less transport energy than VRF. Moving BTUs in VRF systems can represent as much as 30% of the total electrical cooling energy demand, compared to only 20% in hydronics-based systems (Cunniff, 2013).

**FIGURE 1**

**DISTRIBUTION / PUMPING ENERGY**

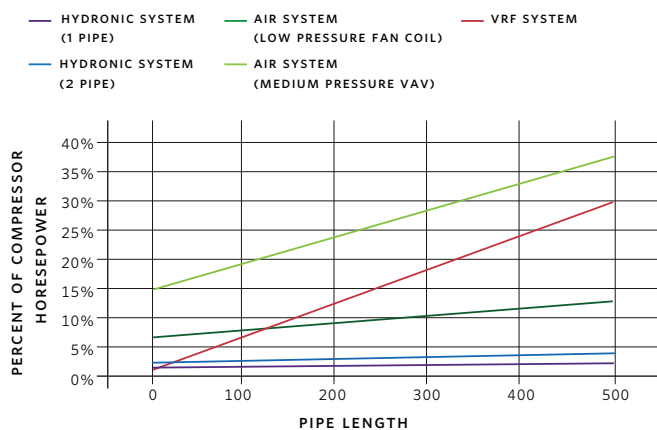

It is important to note that the above summary of distribution energy vs pipe length does not account for Design Envelope integration. Where specific Armstrong solutions are employed, pressure drop across a hydronic system can be further reduced, decreasing energy required for distribution. For example, Armstrong’s Flo-Trex valve (FTV) reduces the need for three separate valves (circuit balancing, isolation and check valves), along with decreasing their associated pressure drops. Similarly, a suction guide reduces the need for in-line strainers, long-radius elbows and superfluous piping, further reducing piping and associated pressure drop. Pressure drop reductions across system components decrease the overall transport energy requirements of the system.

**2.1.2 PART LOAD PERFORMANCE**

With respect to variable speed technology (variable speed compressors and ecm’s on blowers), the assertion that VRF offers a benefit over hydronics is inaccurate. Hydronic system components have long since integrated variable speed, and in the case of Armstrong’s Design Envelope, improved on the technology.

For example, pumps, which move working fluid between source and load, have long been offered with variable speed drives (VFD’s), with the option to further increase efficiencies by upgrading to ECM’s.

Design Envelope technology vastly improves part-load efficiency and turndown ratio in hydronic systems using sensor-less controls and integrated intelligent variable speed technology. Design Envelope pumps with integrated drives have been shown to provide 20% to 25% greater energy savings than traditional pumps fitted with variable speed drives. Similarly, by adding integrated variable flow controls to Design Envelope pumps, energy savings can be as high as 78%.

To maintain efficiency across multiple pumps, despite the wide flow range, Design Envelope pumps employ best-efficiency sequencing which ensures optimal energy savings (John F Allan, 2009). This is done by modulating pump operation and staging pumps on and off based on efficiency rather than speed.

In addition to pumps and controls, hydronics is, for the most part, standardizing on variable speed technology. For example, boilers have combined high turndown ratios (boilers now offer 20:1 turndown) with ECM blowers and O<sub>2</sub> sensors that provide feedback to burner controls to maximize combustion efficiency (U.S. Department of Energy, 2014). Chillers have similarly integrated variable speed controls for their compressors and have even adjusted condenser/evaporator design and control logic to allow for variable hydronic flow. It is noteworthy that part-load capabilities can be enhanced by running multiple units in parallel, effectively offering limitless turndown ratios. That is to say, full system flow/load is defined by the maximum combined flow/load of all operational units, while minimum system flow/load is defined by the minimum flow/load of a single unit. This is true for all hydronic components, including pumps, chillers, cooling towers and boilers.

An added benefit of running multiple units in parallel that is unique to hydronics is redundancy. In traditional hydronic systems, redundancy is often achieved by employing an N+1 design standard; in other words, the number of units installed is one more than the number required to satisfy the full load. For example, three chillers may be installed, each sized to address

50% of the total system load. Similarly, two pumps may be installed, each capable of handling 100% of the design flow and head. In this way, if one component were to fail, the system could still provide the required output.

However, there is a trade-off to redundancy. Increasing the number of parallel units increases capital cost, while upsizing individual components limits turndown, both of which increases energy consumption. Therefore, designers must balance the need for redundancy by adding equipment (increased redundancy and capital cost) and/or upsizing equipment (increased redundancy and limited turndown).

Fortunately, Design Envelope technology addresses these concerns by optimizing plant operation (leading to a reduction in energy consumption of up to 15%) for any and all combinations of equipment capacities and/or quantities, while reducing first cost (by up to 25%).

As an example, a system may have three cooling towers (each with 50% of total capacity), two chillers (each providing 55% of capacity) and three Design Envelope pumps (each with 40% capacity) connected using Armstrong’s integrated control technology. If a chiller were to fail, the inclusion of Design Envelope technology would allow the system to provide more than 80% of the design load (as opposed to only 45%) for 95% of design conditions.

**2.2 RATED EFFICIENCY**

Another focus of the VRF industry is the claim that VRF is rated for higher efficiencies than hydronic systems by independent institutions and standards. However, when the basis of these claims is explored, it becomes evident that actual efficiencies are far below rated efficiencies.

A review of nine test installations in the U.S. (see **FIGURE 2**) showed VRF rated heating efficiencies **exceeded actual operating efficiency in the field by 30% to 60%, with an average of approximately 48%** (Hydronics Industry Alliance).

**FIGURE 2**  
Normalized IEER For VRF System Tests (Real World IEER vs. AHRI Published IEER)

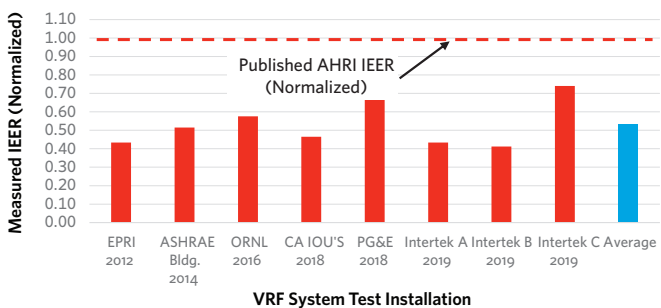

Note that COP/EER (Coefficient of Performance/Energy Efficiency Ratio) cannot be taken at face value when comparing different technologies. This is because of the distinct test standards used for each technology.

For example, heat pump heating COP’s are based on AHRI 340/360, which tests at an outdoor temperature of 44.6°F DB (42.8 °F WB) and indoor temperature of 68°F DB (59°F WB), in moderate climates (AHRI, 2015).

In contrast, VRF heating COP’s are based on AHRI 1230, which tests at an outdoor temperature of 47°F DB (43°F WB), indoor temperature of 70°F DB (60°F WB), total piping lengths less than 150 ft (typically 25 ft) and maximum elevation differences between condenser and evaporator of 0 ft (AHRI, 2010).

When we examine the following elements of VRF energy efficiency standards, it is apparent that published COP’s/EER’s often differ from real-world installations:

- Piping length
- Part load operation
- Outdoor Air Temperature (OAT)

**2.2.1 PIPING LENGTH**

ASHRAE 1230 rates VRF using 25 ft of piping and no elevation change. However, as mentioned above, VRF compressors are responsible for transporting refrigerant from source to load (and back again), therefore piping length has a direct impact on heating/cooling output vs energy input.

The effects of piping length on cop can be seen in **FIGURE 3** below: modeling VRF using a constant discharge pressure control method showed **lengthening horizontal pipe will reduce cop apparently in heating mode, even under part-load conditions** (Li, 2017).

**FIGURE 3**

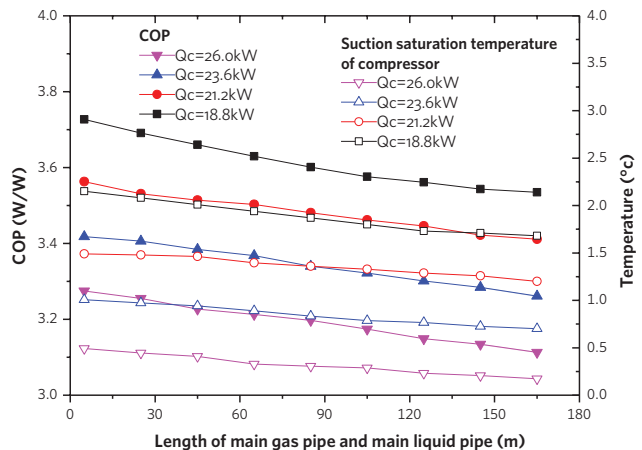

Although the effects of refrigerant piping length on COP are felt by all DX equipment (including those contained within hydronic systems), these effects are negligible. The reason is that the refrigerant circuits on these types of equipment are limited to the equipment itself. For example, in a packaged AHU, the refrigerant circuit extends from compressor to coil and back again, – both of which are contained within the package. In a chiller, the refrigerant circuit goes between evaporator barrel and condenser barrel. Because the distance between these components is so small, the resulting pressure drop and corresponding effect on COP can be disregarded.

**2.2.2 PART LOAD OPERATION**

Part-load vs full-load operation is another factor that directly impacts actual efficiency as it relates to rated efficiencies. This is true because typical HVAC systems (whether VRF or hydronic) “operate at less than 60% capacity 90% of the time or more” (Armstrong Fluid Technology, 2019), see **FIGURE 4** below.

**FIGURE 4**

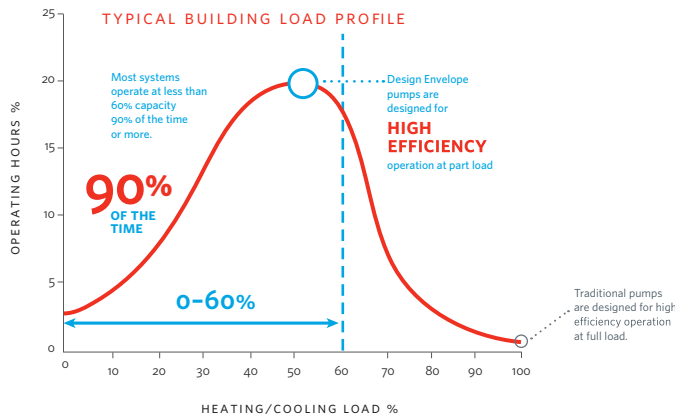

As seen in **FIGURE 5**, which was produced by REHVA ( Federation of European Heating, Ventilation and Air Conditioning Associations), the energy efficiency ratio (EER) of VRF degrades at approximately 45% capacity due to the aforementioned need for oil return, combined with residual electricity consumption resulting from controls. At around 15% capacity, EER is significantly affected by compressor cycling (Courtney, 2014).

**FIGURE 5**

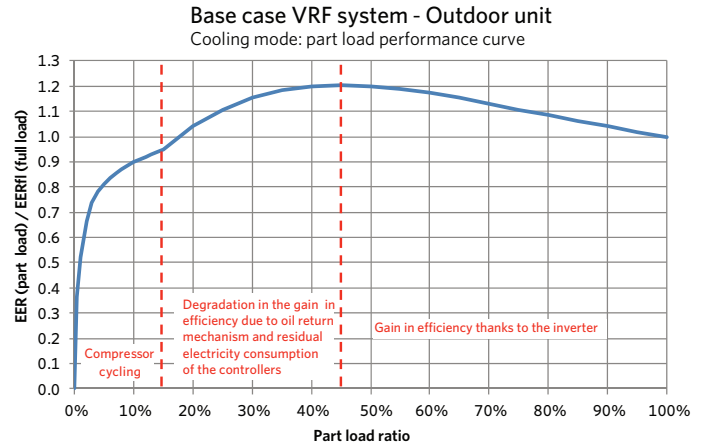

The opposite is true for hydronic systems. Energy efficiency can increase in part-load conditions.

As shown in **FIGURE 6**, chiller plants consume a significant (40%) proportion of energy required by hydronics-based HVAC systems. Of that, the chiller itself consumes the majority (64%) of energy. (PSG Facility Services, n.d.)

**FIGURE 6**

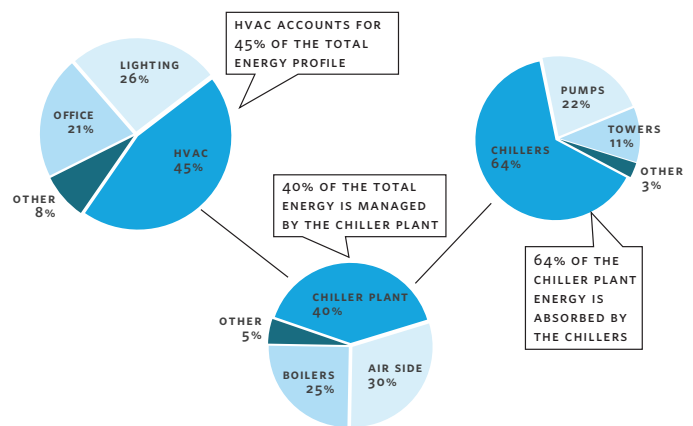

Thus, increases in chiller efficiency for part-load conditions lead to overall system efficiency increases in part-load conditions. This can be seen in **FIGURE 7** for the latest type of chiller (oil-free magnetic bearing centrifugal), which reduces the kilowatts of energy required per ton of output by more than 50% when going from 100% load to 20% load (Smardt, 2011).

FIGURE 7

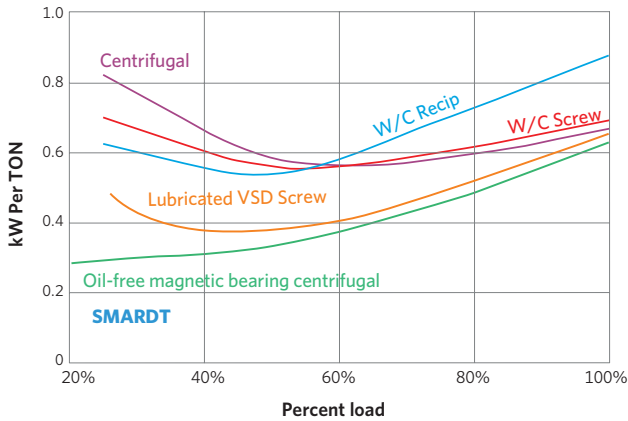

It is important to note that for large buildings, chillers are rated higher than VRF with respect to cop. Chillers have higher cop's than any other cooling system, with ratings up to 7.2, twice that of VRF systems, which typically have a cop of ~4.2 (ASHRAE, 2016).

As shown in FIGURE 6, pumps constitute the second largest energy demand in chiller plants. This is true for all subcategories of hydronic systems, even in boiler plants, where the largest electrical energy consumption is from pumping packages.

By using Design Envelope pumps as opposed to traditional variable speed pumps, the overall energy efficiency of an HVAC system can be further increased by optimizing selection and control for part-load operation.

### 2.2.3 OUTDOOR AIR CONDITIONS

One final consideration in rated efficiencies vs actual efficiencies is the fact that **heating capacity and efficiency of outdoor units are highly dependent on the ambient air conditions** (Schuetter, 2017).

As outdoor temperatures decrease, compressor speeds increase to maintain the load in the building. The increased speed results in increased energy consumption, which is not captured in rated COP or EER values.

For example, for most of the heating season (below 50°F DB) the actual cop is approximately 30% below the rated cop of a VRF system. At very low temperatures (less than -10°F DB), **the ratio rapidly decreases, resulting in significant heating efficiency degradation** (Schuetter, 2017).

Additionally, VRF condensers go through defrost cycles in periodic intervals. During these cycles, the compressors are ramped up to maximum speed, consuming more energy - energy that is not accounted for in overall efficiency ratings.

The effects of OAT and defrost cycles on VRF cop can be seen in FIGURE 8: at an outdoor temperature of 47°F DB (AHRI 1230 Standard Outdoor Temperature for testing), the actual cop matches the rated cop. Decreasing the outdoor air temperature to 30°F DB reduces cop by ~30%; further decreases in temperature result in further reductions in COP until -10°F, at which point cop decreases exponentially (Hackel, 2017).

FIGURE 8

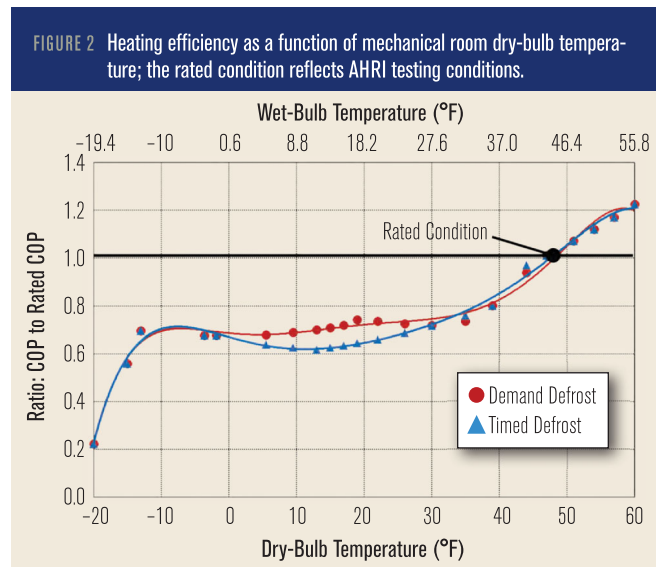

### 2.2.4 CUMULATIVE EFFECT OF RATED VS ACTUAL EFFICIENCY

By consolidating the inconsistencies between rated conditions and actual conditions and making a comparison to a typical hydronic system, it becomes clear that there is significant energy savings, and by extension, operating cost savings, to be had by designing with hydronic systems.

In a two-year study conducted at ashrae Headquarters, the hydronic system (ground source heat pump) consumed 3 times less electrical energy than the VRF system despite serving the same building with similar loads (Arnold, 2014). **On an annualized basis, the VRF system had energy consumption 57% higher than the hydronic system in 2010, 84% higher in 2011 and 61% higher in 2012** (Hydronics Industry Alliance).

The details of the study can be seen in FIGURE 9.



FIGURE 9

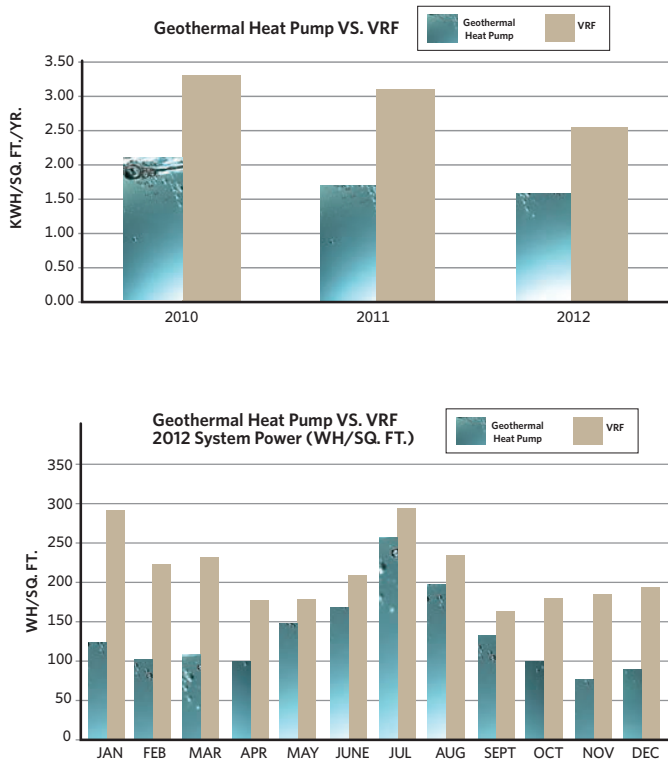

It is important to note, that the energy savings results referenced above are drawn from a comparison to a traditional hydronic system. Further enhancements could have been made by using Armstrong’s Active Performance Management and integrated controls solutions to seamlessly integrate pumps with source side equipment.

By unifying the control algorithms of individual system components towards a common energy efficiency strategy, overall system efficiency can be further increased by up to 60% (Armstrong Fluid Technology, 2015), as seen in **FIGURE 10**

FIGURE 10

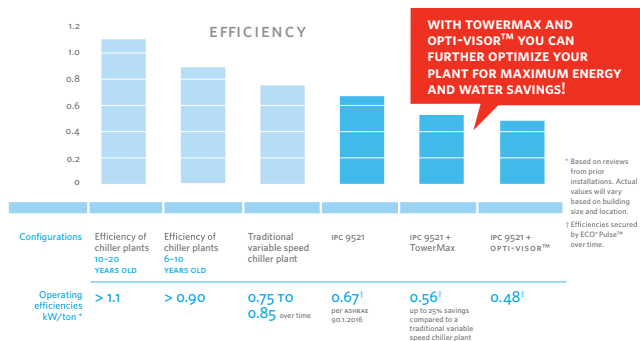

Similarly, by integrating Active Performance Management into hydronic systems, remote monitoring and machine learning can be combined with existing intelligent controls to prevent energy drift. Limiting the impacts of energy drift, which can have compounding effects across an entire hydronic system, can provide energy savings of up to 25%.

### 2.3 MAINTENANCE REQUIREMENTS

According to VRF manufacturers, a single-source supplier for all equipment is advantageous to end users and maintenance personnel. Unfortunately, this is not the case when considering the specialist nature of VRF systems and working fluids or the proprietary nature of components and diagnostic tools.

#### 2.3.1 REFRIGERANT AS A WORKING FLUID

An important consideration that could have significant implications for maintenance and operation of VRF systems is the future availability of required refrigerants.

VRF systems use R-410 which is considered a hydrofluorocarbon (HFC). As per the Kigali Amendment of the Montreal Protocol, signatory countries have made a commitment to **phase down production and consumption of hydrofluorocarbons (HFCs) worldwide** (U.S. Department of State, 2019).

At a recent U.S. Senate Environment and Public Works Committee meeting, Stephen Yurek, President and ceo of the Air-Conditioning, Heating & Refrigeration Institute, provided written testimony that most companies will completely transition from HFC’s by mid-decade because **it is cheaper, easier, and more profitable to transition in one fell swoop.** (Yurek, 2020)

Unfortunately, VRF systems are specifically designed for their refrigerant of choice: R-410 is compressed and expanded to specific pressures and is transported throughout the system via pipes specifically sized for R-410 and its working pressures. For this reason, drop-in substitutes are not feasible.

If R-410 were to be phased out in the market, owners would be forced to pay increasing costs until it was no longer available. At that point, owners would likely be compelled to make a difficult decision: replace their entire system, including distribution piping throughout their entire building, or gamble with the closest available substitute, which would undoubtedly have adverse effects and increase operational and maintenance costs.

As the term suggests, hydronic systems do not use refrigerant as a working fluid and as such are unaffected by the aforementioned concerns. Certain components of hydronics-based systems (chillers, packaged ahu’s, heat pumps, etc.) do use

refrigerant (R-410, R-134, etc.), though these components represent only a small portion of the entire system. Even in the worst-case scenario, where refrigerants are no longer available, maintenance and retrofit requirements would affect only the individual component, rather than the entire system.

### 2.3.2 SPECIALIST REQUIREMENTS

One final consideration in the lifetime cost of hydronics vs VRF is the proprietary nature of VRF systems.

Proprietary VRF systems require **specialized technicians for installation, adjustments and repairs** (DelPiano, 2017). Building owners are therefore dependent on the manufacturer for the life of the system (Hydronics Industry Alliance) for not only executing repairs and supplying replacement parts/equipment but also for diagnosing the issue.

Moreover, **along with higher first costs, VRF systems have a shorter life expectancy. Hydronic systems have been known to last 20 to 25 years, while VRF systems may need to be replaced 10 to 15 years after installation** (DelPiano, 2017).

In contrast, hydronic systems can be diagnosed and modified at any time by any (ideally licensed) mechanical contractor. The flexibility offered by hydronic systems ensures competitiveness throughout the life of the system.

In addition to the flexibility of hydronic maintenance as well as the widely available network of trained and experienced technicians, lifetime costs can be reduced by 40% by using performance tracking software, such as Armstrong's Active Performance Management.

By analyzing small changes in performance (vibration analysis, expected output vs actual output, etc.) and providing service alerts directly to owners or owners' contractors of choice (example in **FIGURE 11**), catastrophic failures that could result in extended downtime and costly repairs can be mitigated. Similarly, maintenance requirements that can be put off without concern allow owners more time to allocate funds and more time to look for competitive offers.

**FIGURE 11**

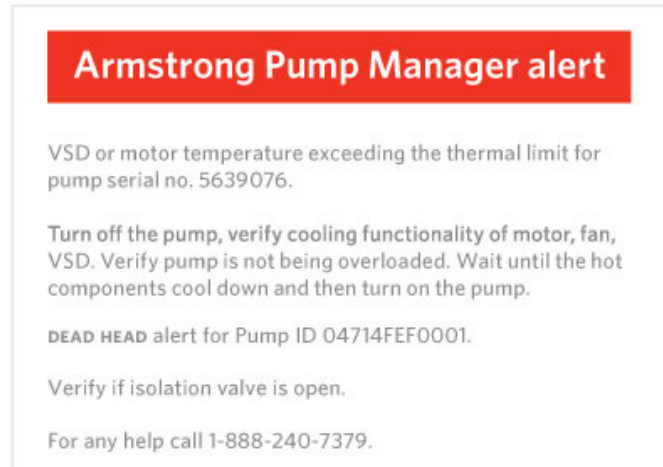

## 3 FIRST INSTALLED COST

It is widely accepted, and even acknowledged by VRF manufacturers, that upfront capital costs for VRF systems are higher than for comparable hydronic systems. **Initial estimates of installed cost premiums of VRF/V systems range from 5% to 20% more than conventional systems for a U.S. office building** (Goetzler, 2004).

This premium on installation costs becomes more apparent in larger systems: VRF systems cost between \$14.90/ft<sup>2</sup> and \$34/ft<sup>2</sup> for schools and apartment buildings, respectively. Comparatively, traditional hydronic systems range from \$11.90/ft<sup>2</sup> to \$31/ft<sup>2</sup> for the same installation types (Park, 2013).

The reason for these cost premiums includes:

- Design limitations
- Installation limitations
- Skewed tendering process

### 3.1 DESIGN LIMITATIONS

Limitations imposed on VRF systems require attention as early as the design stage. These design considerations include:

- Factoring in capacity de-rate
- Ensuring occupant health and safety
- Inclusion of additional ancillary equipment to address limitations of VRF
- Addressing piping limitations
- Maximum system capacity

### 3.1.1 RATED CAPACITY

One important consideration when designing VRF systems is the effect of capacity de-rate on sizing and selecting VRF systems, along with the increase in installed cost due to the need for larger installed capacity than delivered capacity.

The two main factors contributing to capacity loss in VRF systems are outdoor air temperature and piping lengths.

For example, the heating capacity available at 5°F is at best 70% of the heating capacity available at 60°F (Aify).

The full extent of outdoor air temperature and defrost cycles on the output capacity of VRF systems can be seen in **FIGURE 12**, published by a popular VRF manufacturer (Daikin).

**FIGURE 12**

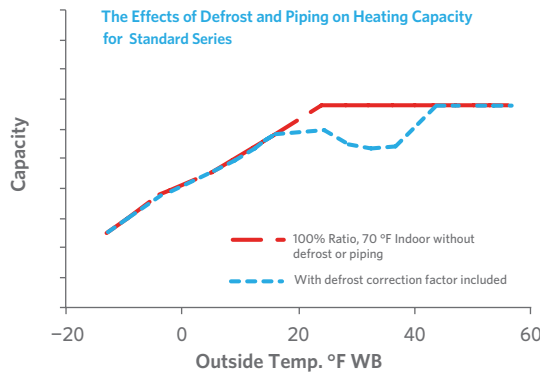

The implication for system design is an increased need for supplemental heat. Designers can elect to design building envelopes with supplemental heat to work in parallel with VRF evaporators. Alternatively, mechanical space can be extended to include outdoor condensers and be retrofitted with space heaters to maintain optimal conditions.

One VRF manufacturer states that design considerations must be made to address a 50% decrease in heating capacity at 0°F compared to rated conditions (Mitsubishi Electric, 2012). Furthermore, **FIGURE 13** shows a balance point at which supplemental heat is no longer adequate and a building’s full heating load must rely on alternative system types (Daikin).

**FIGURE 13**

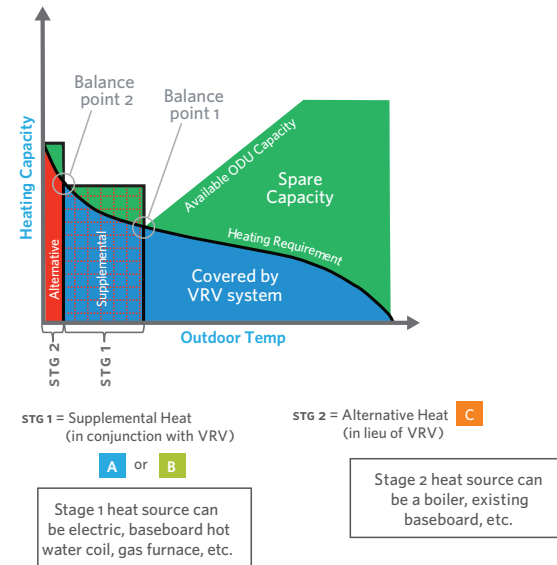

This added energy consumption (often supplied via inefficient electric heat) is ignored when rating COP/EER values but will directly impact the total energy consumed by an HVAC system to maintain design conditions.

A less commonly discussed cause of system capacity de-rate is piping length. As shown in **FIGURE 14**, rated capacity starts to decrease when pipe length goes beyond 25 ft (as per ASHRAE 1230 standards). By the time piping length has reached 600 ft, 10% of total capacity has already been lost (Artis, 2014). If we linearly extrapolate this to the average maximum piping length for VRF systems (3,281 ft), we see that more than 50% of capacity is lost to piping lengths.

**FIGURE 14**

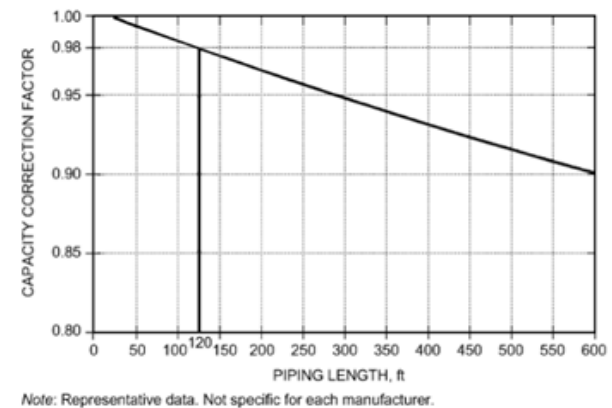

Hydronic systems do not experience capacity losses related to piping length. The primary reason is the decoupling of the distribution circuit (hydronic piping throughout the building)

from the internal circuits of source-side equipment (refrigerant circuits for chillers and AHU's, flue gas circuits in boilers' heat exchangers, etc.).

It is important to note that capacity losses can occur due to convective and radiative heat transfer through the aforementioned distribution piping. However, hydronic code requirements mandate the use of insulation, which reduces these losses for heating systems and gains for chilled water systems to negligible amounts: for **hot-water systems operating below 200°F, the 2015 IECC requires insulation thicknesses between 1" and 2"** (Crall, 2015).

### 3.1.2 OCCUPANT HEALTH & SAFETY

Another limitation is the volume of refrigerant contained within VRF systems and related health concerns.

As noted, VRF systems span the entire envelope of a building, and the technology requires hundreds (if not thousands) of feet of piping to be filled with pressurized refrigerant. This property of VRF systems **is of special concern because it could potentially discharge all of the comparable refrigerant charge into one room** (Duda, 2012).

ASHRAE 15 limits the total volume of R-410a contained in a system relative to the volume of the smallest space served by the system (Duda, 2012). This code is in place to protect occupants from the potentially lethal effects of refrigerant-induced asphyxiation, which is especially important for VRF systems as they typically use a refrigerant that is colourless and odourless (Cunniff, 2013).

Despite standards in place to address the effects of refrigerant leaks on occupant health and safety, concerns with VRF systems persist. For example, in 2017 the U.S. Department of Defense issued a **directive stating that VRF systems would no longer be permitted in U.S. Air Force facilities, and while not forbidden in Army facilities, they would be strongly discouraged** (Turpin, 2018). A bulletin from the U.S. Army Corps of Engineers offered the following explanations:

- Concern over refrigerant concentration, as a typically sized vrf system contains enough refrigerant to potentially asphyxiate occupants in the event of a refrigerant leak;
- Difficulty in locating refrigerant leaks due to long refrigerant lines that are common with VRF systems; and
- Proprietary controls used by many VRF systems, which conflict with the legal requirement of using open protocol systems (Turpin, 2018).

Unfortunately, the risk to occupant health and safety is often downplayed, in part due to the fact that R-410a (the refrigerant most commonly used in VRF systems) is only classified as a Group 1a (non-flammable and non-toxic) substance. Additional claims of mitigated risk come from the inclusion of simplistic design considerations, such as door diffusers and common ceiling plenums.

These beliefs are misplaced because the threat of R-410 does not come from its inhalation, but rather its ability to displace oxygen, which is a direct result of its higher density (Cunniff, 2013).

Because of this higher density, door diffusers and common ceiling plenums would actually exacerbate the effects of refrigerant leak by providing a path for oxygen to be pushed out of a space, thereby allowing more refrigerant to leak in.

Therefore, for installations that serve a wide range of zone sizes, VRF systems costs increase as designers must either include extensive leak detection equipment in their design or make design changes to their HVAC equipment by redesigning a single system to become multiple systems (to reduce total refrigerant volume per system) or combining multiple zones using ducted evaporators (to increase the volume of the smallest space), which requires additional ducting.

Comparatively, hydronic systems are not limited in size. For example, district energy plants combine multiple buildings using hydronic loops. Although there is risk of damage in the event of a leak, unlike refrigerant, water is not a **silent killer**.

It is important to note that ASHRAE 15 does apply to all system types and is not limited to VRF systems. However, refrigerant use is limited to significantly smaller refrigerant circuits contained within hydronic equipment (chillers, heat pumps, packaged AHU's, etc.). For this reason, additional design considerations are limited to mechanical space. For example, plans for small mechanical rooms with relatively large (capacity) chillers often include refrigerant leak detection. Minor changes such as this require very little design consideration and have an insignificant effect on the full system design.

### 3.1.3 ANCILLARY SYSTEMS

Another design constraint for VRF systems is the limitation on scope. VRF systems are only able to address heating and cooling requirements. Building designs must still include ancillary systems (which are often based on hydronics) for other functions.

For example, VRF systems **are not designed to extract large amounts of moisture from the air** (Song, 2019). This restriction may be of particular importance in regions with high humidity: ventilation standards will still require a minimum volume of fresh air to be circulated in the occupied space. Because **VRF units are limited by their smaller coils** (Song, 2019), a dedicated AHU with corresponding ducting may be required.

This not only increases the installed cost of projects, it also invalidates many of the cited benefits of VRF, including ceiling space savings, smaller mechanical footprint, and single-source supplier.

Similarly, in colder regions, buildings that require snow-melt systems would need a hydronic system for that load. Where source-side hydronic equipment is already required to supply the snow-melt system, the capital opportunity cost of the investment decision would be changed significantly.

This logic can be applied to domestic hot water (DHW) systems. **FIGURE 15 shows an example of how to set up a tankless water heater as a heat source and for your domestic hot water. This is called a closed-loop heating system with domestic water** (HouseNeeds, n.d.). Again, the cost of upsizing the source-side equipment and adding a double-wall heat exchanger to an existing hydronic heating circuit is significantly lower when considering the sunk cost of the DHW system.

FIGURE 15

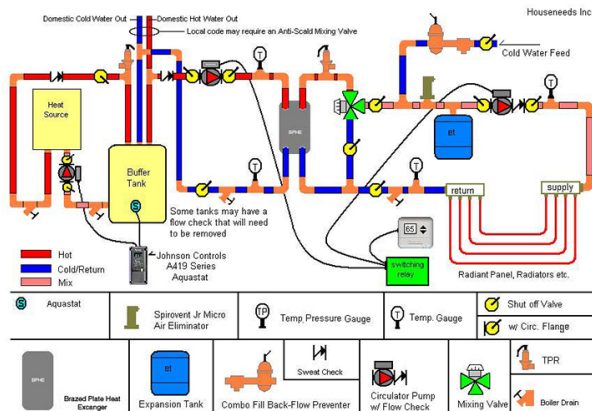

As demonstrated, hydronic systems can address multiple load types with common infrastructure requirements. Therefore, the cost of adding these hydronic subsystems to an existing hydronic system is significantly less than adding the hydronic subsystem to an existing VRF system. Ultimately, having two separate systems for two distinct functions would make the installed costs higher.

### 3.1.4 PIPING RESTRICTIONS

There are also hard limits on the piping design/layout of VRF systems. For example, VRF systems are limited to ~1,000 m (3,280 ft) of total piping (excluding suction line) and 40 m (130 ft) of vertical separation between condenser and evaporator, when the condenser is below the evaporator (Daikin, 2017).

Unfortunately, as shown in **FIGURE 16**, the limitations on length and vertical separation are not the only restrictions that affect VRF piping. For large systems that use multiple evaporators, the interdependency of the various restrictions leads to extra design work and related project costs.

FIGURE 16

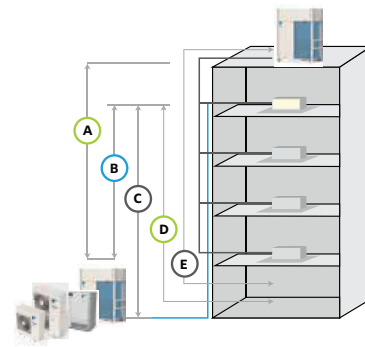

	LIQUID LINE MAX (FT)	HEAT PUMP	HEAT RECOVERY	SERIES	WATER COOLED	(36)	(48-60)
A	Vertical Drop	164 (295)*	164 (295)*	164 (295)*	164	98	98
B	Between IDU	100	100 (49)†	100 (49)†	49	33	49
C	Vertical Rise	130 (295)*	130 (195)*	130 (195)*	130	98	98
D	From 1st Joint	130 (295)**	130 (295)**	130 (295)**	130 (295)**	130	130
E	Linear Length	540	540	540	390	164	230
	Total Network	3280	3280	1640	980	820	984

\* Setting adjustment on condensing unit required.  
 \*\* Fan coil distance differentials need to be met.  
 † Possible refrigerant noise can be mitigated (via setting adjustments on ODU) when linear length exceeds 390 ft.

This contrasts with hydronic systems, which can be as large as needed and have no restriction on pipe length. For larger systems, the only consideration is an increase in pump sizing to accommodate higher pressure drops and in pipe sizing to accommodate the increased flow rate of the working fluid.

As noted, hydronic systems offer a wide range of feasible velocities, allowing for piping to be sized in accordance with design intent. For example, to minimize first cost (at the expense of higher lifetime cost), hydronic piping can be downsized (causing greater pressure drop). Conversely, if long-term lifetime cost is the primary focus of the design, pipe sizes can be increased (at the expense of higher first cost) to ensure minimal flow velocities and corresponding pressure drops.

Velocity in a hydronic system is a function of flow rate, which is a function of load and temperature differentials. Both flow rate and velocity can be adjusted, provided effective heat transfer and system component operation (differential pressure requirements for valves, minimum velocities for air purgers, etc.) are ensured.

Additional flexibility arises from integrating Design Envelope accessories such as suction guides, air separators and filters, into hydronic systems. This is a result of the fundamental principle of Design Envelope technology, which operates efficiently in a wide range of flow and head conditions, ensuring optimal operation and efficiency despite variations in system demand.

VRF systems, on the other hand, are severely limited in design flexibility. Pipe size is dictated by manufacturers based on system piping lengths, total capacity and capacity of evaporators served through the relevant pipe section. Furthermore, pipe sizing standards vary by manufacturer, which further limits design.

**3.1.5 MAXIMUM SYSTEM CAPACITY**

A final design consideration is the limitation of total system capacity. Individual VRF systems are limited to ~4.4 tons (528 MBH) of cooling capacity or ~49.5 tons (594 MBH) of heating (Samsung HVAC); above these capacities, a separate system is required, including independent piping and controls networks, additional condensers and separate electrical work.

Comparatively, hydronic systems have far larger capacities per unit. For example, most commercial water tube boiler manufacturers offer capacities up to ~666 tons (8,000 MBH) per boiler, with some offering up to 1,000 tons (12,000 MBH). Similarly, individual chillers can easily reach 2,000 tons (24,000 MBH) of cooling, while standard commercial cooling towers can offer capacities in the range of 2,189 tons (26,268 MBH).

**3.2 INSTALLATION LIMITATIONS**

Cost differences for installation are primarily the result of the requirement for more complicated refrigerant management systems and controls in VRF systems (Cunniff, 2013). Because refrigerant is the working fluid of VRF systems, and all system components must be connected to a single control system, more stringent installation requirements (mechanical, electrical and controls) exist. **Special care in installation is necessary to ensure that contaminants don't enter the system and damage the compressor** (Hydronic Industry Alliance).

**3.2.1 MECHANICAL CONSIDERATIONS**

Each installation step of VRF systems requires extra care and attention, and the techniques used extensively in hydronic system installations (to minimize installation time and cost) cannot be used in VRF systems. **VRF piping requires mechanical fittings, brazing and soldering on-site** (DelPiano, 2017). The time required to execute this work depends on the installer's level of expertise (DelPiano, 2017).

In comparison, hydronic systems can use pressure fittings or mechanical couplings, which require minimal expertise and were adopted by the hydronics industry to expedite the installation process.

Installation requirements and costs are further reduced by integrating Design Envelope technology. For example, Design Envelope Vertical In-Line pumps eliminate the need for house-keeping pads and the associated subtrades required to pour concrete or size acoustic requirements. Similarly, integrated intelligent variable speed controllers eliminate the need for harmonic filters and the labour required to analyze electrical interference in the mechanical room. Sensorless technology also reduces the capital and labour costs of installing, wiring and calibrating sensors.

For VRF systems, **installers must be qualified to work with refrigerants under extremely high pressure and be knowledgeable about refrigerant piping locations under their jurisdiction's International Mechanical Code (IMC), as well as leak detection and ventilation requirements of ASHRAE Standard 15** (DelPiano, 2017).

These requirements often demand a VRF specialist with factory-certified training specific to each manufacturer. In many jurisdictions, VRF installers are required to hold specific licenses or tickets prior to commencing installation to ensure they are qualified to work with high-pressure refrigerant systems.

With respect to construction materials, as shown in **FIGURE 17**, VRF systems must be installed using copper piping, whereas hydronic piping offers many options (Siegenthaler, 2015).

**FIGURE 17**

PIPING OPTIONS IN HYDRONIC SYSTEM	PIPING REQUIRED IN VRF SYSTEM
COPPER	COPPER
BLACK IRON/ STEEL	
STAINLESS STEEL	
PEX	
PEX-AL-PEX	
PERT	
POLYPROPYLENE (PP-R)	

As well, because of the high fluid pressures and temperatures of refrigerants in VRF systems, the grade of copper to be used must meet ASTM B280 standards and be suitable for an operating pressure of 551 psig (LG).

In considering the cost of various piping materials per linear foot, distribution piping for hydronic systems is significantly less than that of VRF systems, even after accounting for the fact that hydronic piping is approximately 3 times larger for equivalent capacities. For example, ASTM B280 rated copper cost \$346.12 for 50 ft of Y tubing (Grainger Canada, 2020), whereas 60 ft of 2½" schedule 40 carbon steel piping (typically used for hydronic heating applications) cost only \$22.80 (Global Technology & Engineering, 2020). If we normalize per linear foot, the cost of hydronic piping is ~10% of the cost for VRF piping for comparable capacities.

Another consideration, which often causes delays, relates to the aforementioned design limitations on piping layout. Installations rarely follow design drawings to the letter, and installers need the flexibility to make minor changes on the fly.

For example, a subtrade may shift an installation away from the original design location, creating interference with hydronic piping. In such cases, installers need the flexibility to shift system piping in response.

This can be done easily in hydronic systems (rarely requiring oversight or approval), and if best practices are followed, so that changes are minor and the budget is unaffected, there will likely be minimal effect on equipment selection.

Furthermore, balancing of hydronic systems after installation is standard practice to address deviations from design and ensures the effects of these deviations are accounted for, reducing adverse effects on system performance.

For VRF systems, these small changes must be reviewed and approved by the manufacturer. For especially large VRF systems that are already close to the limits of VRF piping restrictions, these changes may not be approved (despite criticality and urgency) as piping may fall outside of manufacturers' stated limitations.

As mentioned, there are several piping restrictions for VRF systems, which are interdependent. The closer a piping change is to the main branch and condenser, the more important it becomes to consult with the manufacturer.

### 3.2.2 CONTROLS CONSIDERATIONS

VRF manufacturers frequently promote controls configuration as an advantage of their systems. These systems typically daisy-chain all components. In this configuration, all components of the system are completely integrated and controlled via a central controller in the condensing unit. However, this can lead to increased installation and commissioning time as well as increased downtime if failure or error occurs.

As an example, compressors determine refrigerant flow rate and compression ratio based on the net demand at each position of electronic expansion valves (located on each evaporator).

If a disconnect exists in a daisy-chained system, all components after the broken connection become invisible to the main control unit. For this reason, some VRF systems will shut down completely as a safety measure even if a single disconnect occurs, regardless of how many other units are affected. This can lead to costly downtime.

### 3.2.3 TENDER CONSIDERATIONS

Another facet of VRF installation that is often positioned as a benefit but ultimately has negative consequences is the fact that VRF systems are unique and use proprietary designs and software, provided in their entirety by a single supplier.

From as early as the system design stage, engineers/designers are forced to rely heavily on individual VRF suppliers to review and approve designs because VRF systems have unique and proprietary constraints, controls and design criteria, all of which affect the sizing process.

When a tender is released, VRF installers and suppliers will often include additional margin (as a contingency) to compensate for lack of familiarity (Goetzler, 2004) and deviations that may occur from basis-of-design. For example, a tender may be laid out using ½ inch refrigerant piping, but another VRF supplier may require the same length of piping to be ¾ inch.

Because the basis-of-design supplier is the only manufacturer confident (at the time of bidding) of not having to deviate from the original design, they ultimately have an advantage that can be translated into increased bid price (which maximizes equipment cost while ensuring the tender is secured) at the owner's expense.

#### 4 CONCLUSION

Although VRF systems offer benefits to owners and engineers, it is evident that the extent of those benefits is largely misunderstood and overestimated.

A critical analysis of actual VRF installations against marketing claims leads to the conclusion that the claimed benefits of VRF are not realized in the final lifetime costs and system performance.

Moreover, claims of VRF's advantages over hydronic systems do not consider developments made in hydronic technology over the last 10 years. Hydronic systems readily address the limitations of VRF's claimed benefits, and incorporation of Design Envelope technology increases these benefits.

Hydronic systems using Design Envelope technology:

- Waste less energy on transporting heating/cooling BTU's
- Improve part-load capabilities and part-load efficiency as well as offer greater redundancy
- Are less affected by system design considerations (piping length, outdoor air conditions, etc.)
- Avoid concerns pertaining to occupant health and safety
- Contribute to systems being more future-proof and resilient
- Offer an expansive network of knowledgeable and experienced installers and service agents
- Address a wide variety of load types
- Provide higher maximum capacity
- Support greater flexibility in design and installation
- Allow for more competitive tenders
- Are easier to diagnose, service and maintain
- Do not mandate specialized (manufacturer-specific) training

For these reasons, the lifetime operating cost savings and first installed cost savings offered by hydronic systems, and in particular by Design Envelope technology, are far greater than those offered by VRF systems.



## 5 REFERENCES

- (2020). Retrieved from Global Technology & Engineering: <https://www.globaltecheng.com/ProductCart/pc/2-5-Schedule-40-Carbon-Steel-Pipe-13p4615.htm>
- Afify, R. (n.d.). Designing VRF Systems. Retrieved from ashrae Philly: [https://ashraephilly.org/images/downloads/CTTC\\_Articles/1405\\_cttc.pdf](https://ashraephilly.org/images/downloads/CTTC_Articles/1405_cttc.pdf)
- AHRI. (2010). 2010 Standard for Performance Rating of Variable Refrigerant Flow (VRF) Multi-Split Air-Conditioning and Heat Pump Equipment. Retrieved from ahri Standard 1230: [http://www.ahrinet.org/App\\_Content/ahri/files/standards%20pdfs/AHRI%20standards%20pdfs/AHRI%20Standard%201230%20-%202010.pdf](http://www.ahrinet.org/App_Content/ahri/files/standards%20pdfs/AHRI%20standards%20pdfs/AHRI%20Standard%201230%20-%202010.pdf)
- AHRI. (2015). 2015 Standard for Performance Rating of Commercial and Industrial Unitary Air-conditioning and Heat Pump Equipment. Retrieved from AHRI Standard 340/360: [http://www.ahrinet.org/App\\_Content/ahri/files/standards/ahri/AHRI\\_Standard\\_340-360\\_2015.pdf](http://www.ahrinet.org/App_Content/ahri/files/standards/ahri/AHRI_Standard_340-360_2015.pdf)
- Alliance, H. I. (2014). Don't Believe VRF Manufacturers Claims of Superior Energy Efficiency. Retrieved from IAPMO: [https://www.iapmo.org/media/3458/water\\_more\\_efficient\\_than\\_VRF.pdf](https://www.iapmo.org/media/3458/water_more_efficient_than_VRF.pdf)
- Armstrong Fluid Technology. (2015). ipc 9521 Integrated Plant Control System for water cooled chiller plant automation.
- Armstrong Fluid Technology. (2019). Armstrong Fluid Technology. Retrieved from Design Envelope Intelligent Variable Speed Pumps: [https://armstrongfluidtechnology.com/-/media/documents/sales-and-marketing/solution-outlines/100-11\\_designenvelope\\_brochure.pdf?la=en&display=1](https://armstrongfluidtechnology.com/-/media/documents/sales-and-marketing/solution-outlines/100-11_designenvelope_brochure.pdf?la=en&display=1)
- Arnold, S. (2014). Study: Geothermal Heat Pumps Outperform VRF at ashrae Headquarters. hpac Engineering.
- Artis, B. (2014). ASHRAE NY. Retrieved from Variable Refrigerant Flow 101: [https://ashraeny.org/images/meeting/022817/variable\\_refrigerant\\_flow\\_101\\_02.28.2017.pdf](https://ashraeny.org/images/meeting/022817/variable_refrigerant_flow_101_02.28.2017.pdf)
- ASHRAE. (2016, March). Refrigerators 3: Chillers vs VRF part 2. Retrieved from ashrae Universitas Indonesia Student Branch: <https://ashrae.eng.ui.ac.id/2016/03/11/refrigerators-3-chillers-vs-VRF-part-2/>
- Courtesy, S. (2014, 02). Performance of Variable Refrigerant Flow (VRF) Systems. rehva Journal. Retrieved from rehva.eu.
- Crall, C. P. (2015). Insulation Outlook. Retrieved from Understanding Thermal Systems: Hydronic Heating and Cooling Systems: <https://insulation.org/io/articles/understanding-thermal-systems-hydronic-heating-and-cooling-systems/>
- Cunniff, G. (2013). Applying Refrigerant Codes. hpac Engineering.
- Daikin. (2017). vrv Reference Guide. Retrieved from Daikin AC: <http://www.daikinac.com/content/assets/DOC/Product%20Brochures/2017/vrvreferenceguide0117.pdf>
- Daikin. (n.d.). vrv Applications in Extreme Climate Conditions.
- DelPiano, K. (2017, August). Hydronics vs VRF — which, when and why? Radiant & Hydronics. Duda, S. W. (2012). Applying VRF? Don't Overlook Standard 15. ashrae.
- Goetzler, W. (2004). Variable Flow and Volume Refrigerant System. ashrae Journal.
- Grainger Canada. (2020). Retrieved from <https://www.grainger.ca/en/product/COPPER-TUBING%2C7-8%22%2C50-FT-L/p/FARCTR14-50>
- Greg Cunniff, P. (2013, July). Guest Editorial: Hydronics offers a cool, comfort advantage. Plumbing & Mechanical Magazine. Retrieved from Plumbing & Mechanical Magazine: <https://www.pmmag.com/articles/95803-guest-editorial-hydronics-offers-a-cool-comfort-advantage>
- Hackel, S. S. (2017). Variable Refrigerant Flow Systems — Design Considerations in Cold Climates. ashrae.
- HouseNeeds. (n.d.). Tankless Water Heater as a Heat Source with Domestic Hot Water. Retrieved from HouseNeeds: <https://www.houseneeds.com/learning-center/tankless-water-heaters-how-to/tankless-heater-as-heat-source>
- Hydronics Industry Alliance. (n.d.). Proof: For Superior energy efficiency - water beats VRF! Retrieved from [https://www.termoshop.com/media/novice/ashrae\\_headquarters\\_case\\_study\\_-\\_hia.pdf](https://www.termoshop.com/media/novice/ashrae_headquarters_case_study_-_hia.pdf)
- Hydronics Industry Alliance. (n.d.). Significant Concerns: ahri/ansi Standard 1230 Performance Rating of Variable Refrigerant Flow (VRF) Multi-Split Air-Conditioning and Heat Pump Equipment.
- John F. Allan, K. K. (2009). Pump Sequencing Optimization. Retrieved from California Polytechnic State University Mechanical Engineering Department: <https://digitalcommons.calpoly.edu/cgi/viewcontent.cgi?referer=https://www.google.com/&httpsredir=1&article=1010&context=mesp>
- LG. (n.d.). LG. Retrieved from Multi V Heat Pump and Heat Recovery Outdoor VRF Condensing Units Installation and Operational Manual: [http://www.lgVRF.ca/fr/installation-manual-multi-v-iii-heat-pump-and-heat-recovery.aspx/Download?filename=VRF-IM-BH-001-US\\_014A03\\_LGInstallManual\\_MVIII\\_20140117093903.pdf](http://www.lgVRF.ca/fr/installation-manual-multi-v-iii-heat-pump-and-heat-recovery.aspx/Download?filename=VRF-IM-BH-001-US_014A03_LGInstallManual_MVIII_20140117093903.pdf)
- Li, Z. (2017). Investigation on effects of piping on heating performance of multi-split variable refrigerant flow systems. 12 th iea Heat Pump Conference. Tsinghua University.

- Mitsubishi Electric. (2012). Application Note 2012: Proper Design of City Multi VRF Air Source Heat Pump Systems for Heating in Low Ambient Conditions. Retrieved from MyLinkDrive: [http://meus1.mylinkdrive.com/sfiles/Application\\_Note\\_2012 -Proper\\_System\\_Design\\_for\\_Low\\_Ambient\\_Heat.pdf](http://meus1.mylinkdrive.com/sfiles/Application_Note_2012_-_Proper_System_Design_for_Low_Ambient_Heat.pdf)
- Park, J. (2013). Comparative Analysis of the VRF System and Conventional hvac Systems, Focused on Life-Cycle Cost. Georgia Institute of Technology.
- PSG Facility Services. (n.d.). hvac Service & Maintenance. Retrieved from psg Facility Services: <http://psgfacilityservices.com/services/hvac-service-maintenance>
- Robert Bean, B. W. (2010). Part 2 History of Radiant Heating & Cooling Systems. ashrae Journal.
- Samsung HVAC. (n.d.). VRF Technical Data Book. Retrieved from Samsung HVAC: [https://s3.amazonaws.com/samsung-files/Tech\\_Files/DVM/DVM+S/Technical+Data+Books/Outdoor+Units/DVM+S/\[TDB\]+VRF+DVM+S+for+America+2AA\\_Ver+1.8\\_191112 .pdf](https://s3.amazonaws.com/samsung-files/Tech_Files/DVM/DVM+S/Technical+Data+Books/Outdoor+Units/DVM+S/[TDB]+VRF+DVM+S+for+America+2AA_Ver+1.8_191112.pdf)
- Schuetter, S. (2017). Variable Refrigerant Flow Systems — Design Considerations in Cold Climates. ASHRAE.
- Siegenthaler, J. (2015). Hydronics Industry Alliance. Retrieved from Modern Hydronics vs Variable Refrigerant Flow Systems.
- Smardt. (2011). Revolutionary Energy Savings: Water Cooled Oil-Free Centrifugal Chillers from Smardt Chiller Group. Retrieved from Smardt: <http://www.smardt.com/docs/SMARTD%20WC%20CATALOGUE%20TD-0080 B.pdf>
- Song, J. (2019). To Employ or Not to Employ VRF. HPAC Magazine, pp. 18–19.
- Swanson, S. (2017, Jul). Go with the flow: Getting the flow rates right with hydronics. Contractor Magazine. Turpin, J. R. (2018). hvac Industry Addresses Military Concerns About VRF Systems. The NEWS.
- U.S. Department of State. (2019). The Montreal Protocol on Substances That Deplete the Ozone Layer. Retrieved from Key Topics — Office of Environmental Quality and Transboundary Issues: <https://www.state.gov/key-topics-office-of-environmental-quality-and-transboundary-issues/the-montreal-protocol-on-substances-that-deplete-the-ozone-layer/>
- U.S. Department of Energy. (2014). Improve Your Boiler's Combustion Efficiency. Retrieved from U.S. Department of Energy: [https://www.energy.gov/sites/prod/files/2014/05/f16/steam4\\_boiler\\_efficiency.pdf](https://www.energy.gov/sites/prod/files/2014/05/f16/steam4_boiler_efficiency.pdf)
- Yurek, S. (2020, April 7). AHRI President and CEO. (S. E. Committee, Interviewer)

**TORONTO**

+1 416 755 2291

**BUFFALO**

+1 716 693 8813

**BIRMINGHAM**

+44 (0) 8444 145 145

**MANCHESTER**

+44 (0) 8444 145 145

**BANGALORE**

+91 (0) 80 4906 3555

**SHANGHAI**

+86 (0) 21 5237 0909

**SÃO PAULO**

+55 11 4785 1330

**LYON**

+33 (0) 420 102 625

**DUBAI**

+971 4 887 6775

**MANNHEIM**

+49 (0) 621 3999 9858