

SERIES 4600 | HORIZONTAL SPLIT CASE PUMP

10 × 8 × 11M | SUBMITTAL

File No: 46.515
 Date: NOVEMBER 28, 2014
 Supersedes: 46.515
 Date: OCTOBER 15, 2013

Job: _____ Representative: _____
 _____ Ordered by: _____ Date: _____
 Engineer: _____ Submitted by: _____ Date: _____
 _____ Approved by: _____ Date: _____

PUMP DESIGN DATA

No. of pumps: _____ Tag: _____
 Capacity: _____ USgpm (L/s) Head: _____ ft (m)
 Liquid: _____ Viscosity: _____
 Temperature: _____ °F (°C) Specific gravity: _____
 Suction: 10" (250 mm) Discharge: 8" (200 mm)

MATERIALS OF CONSTRUCTION

ANSI FLANGE RATING	ANSI 125	ANSI 250
Construction	<input type="checkbox"/> BF	<input type="checkbox"/> BF 250

- Casing:** Cast iron
- Impeller:** Bronze
- Casing wear ring:** Bronze
- Gasket:** Confined non-asbestos fiber
- Bearing frame:** Cast iron
- Coupler guard:** Steel OSHA
- Anti-friction bearings:** Permanently lubricated
- Shaft:** Carbon steel
- Shaft sleeve:** Bronze
- Coupler:** Constant speed: Woods sure-flex or equal
 Variable speed: Woods dura-flex or equal
- Baseplate:** Fabricated steel

MECHANICAL SEAL DATA

ANSI FLANGE RATING	ANSI 125	ANSI 250
Seal type	A21	ARO
Stationary seat	Silicon carbide	Carbon
Rotating face	Carbon	Durchrome
Secondary seal	EPDM	Viton

- Spring:** Stainless steel
- Rotating hardware:** Stainless steel
- Gland plate:** Bronze

MOTOR DESIGN DATA

HP: _____ RPM: _____
 Frame size: _____ Enclosure: _____
 Volts: _____ Hertz: 60 Hz Phase: 3
 Efficiency: NEMA premium 12.12 Other _____ %

MAXIMUM PUMP OPERATING CONDITIONS

- ANSI 125**
 175 psig at 150°F (12 bars at 65°C)
 140 psig at 225°F (10 bars at 107°C)
- ANSI 250**
 300 psig at 150°F (20 bars at 65°C)
 250 psig at 250°F (17 bars at 121°C)

- Tolerance of ±0.125" (±3 mm) should be used
- For exact installation, data please write factory for certified dimensions
- See performance curves on page 3

OPTIONAL EQUIPMENT

SUCTION SIDE REQUIREMENT

- Important (please select)**
 Viewed from motor end
 Right hand (illustrated) Left hand

MOTOR	HORSEPOWER @ RPM		DIMENSIONS INCHES (mm)											WEIGHT*	
	1800	1200	HA	HB	HC		HD	HE	HF	HG	HM		HO	lbs (kgs)	
					ODP	TEFC					ODP	TEFC		ODP	TEFC
284TC	—	15	19.00 (483)	58.00 (1473)	56.38 (1432)	59.26 (1505)	12.00 (305)	8.88 (225)	27.00 (686)	4.00 (102)	22.72 (577)	23.25 (591)	24.90 (632)	1005 (455.9)	1045 (474.0)
286TC	—	20	19.00 (483)	58.00 (1473)	56.38 (1432)	59.26 (1505)	12.00 (305)	8.88 (225)	27.00 (686)	4.00 (102)	22.72 (577)	23.25 (591)	24.90 (632)	1025 (464.9)	1065 (483.1)
324TC	40	—	19.00 (483)	58.00 (1473)	58.94 (1497)	62.06 (1576)	12.00 (305)	8.88 (225)	27.00 (686)	4.00 (102)	24.00 (610)	24.25 (616)	24.90 (632)	1190 (539.8)	1375 (623.7)
326TC	50	—	19.00 (483)	58.00 (1473)	58.94 (1497)	62.06 (1576)	12.00 (305)	8.88 (225)	27.00 (686)	4.00 (102)	24.00 (610)	24.25 (616)	24.90 (632)	1215 (551.1)	1490 (675.9)
364TC	60	—	19.00 (483)	64.00 (1626)	61.19 (1554)	64.34 (1634)	12.00 (305)	8.88 (225)	30.00 (762)	4.00 (102)	25.00 (635)	25.00 (635)	24.90 (632)	1390 (630.5)	1610 (730.3)
365TC	75	—	19.00 (483)	64.00 (1626)	61.19 (1554)	64.34 (1634)	12.00 (305)	8.88 (225)	30.00 (762)	4.00 (102)	25.00 (635)	25.00 (635)	24.90 (632)	1415 (641.8)	1735 (787.0)

PUMP DIMENSIONS
inches (mm)

HL	S	D
13.50 (343)	16.00 (406)	16.00 (406)

*Assembly weight combines pump and motor.

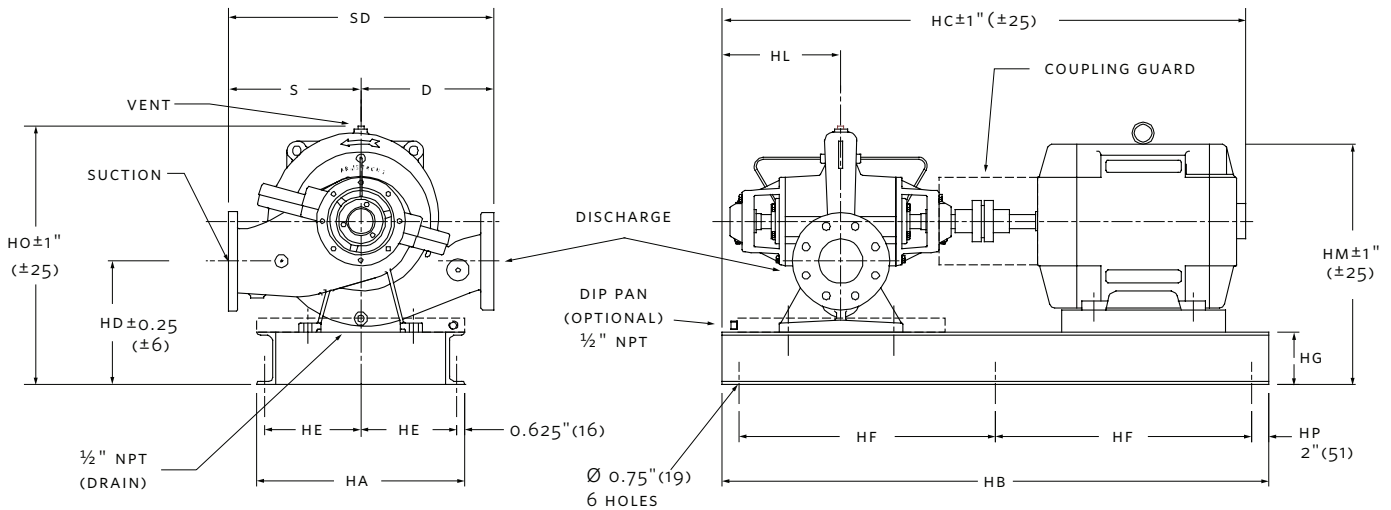

SERIES 4600 PERFORMANCE CURVES

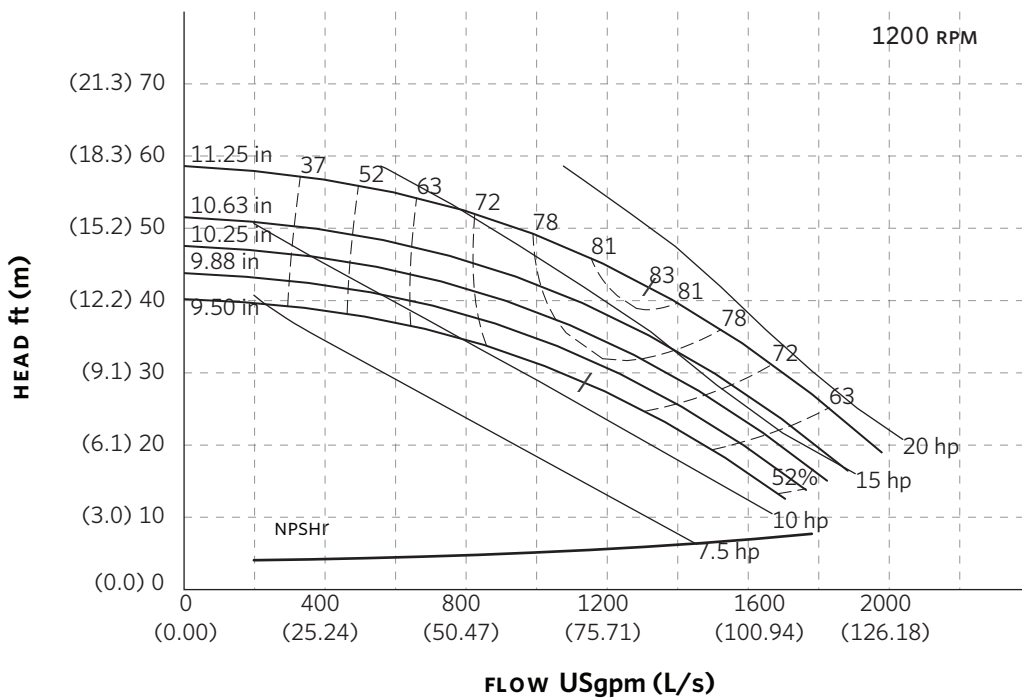
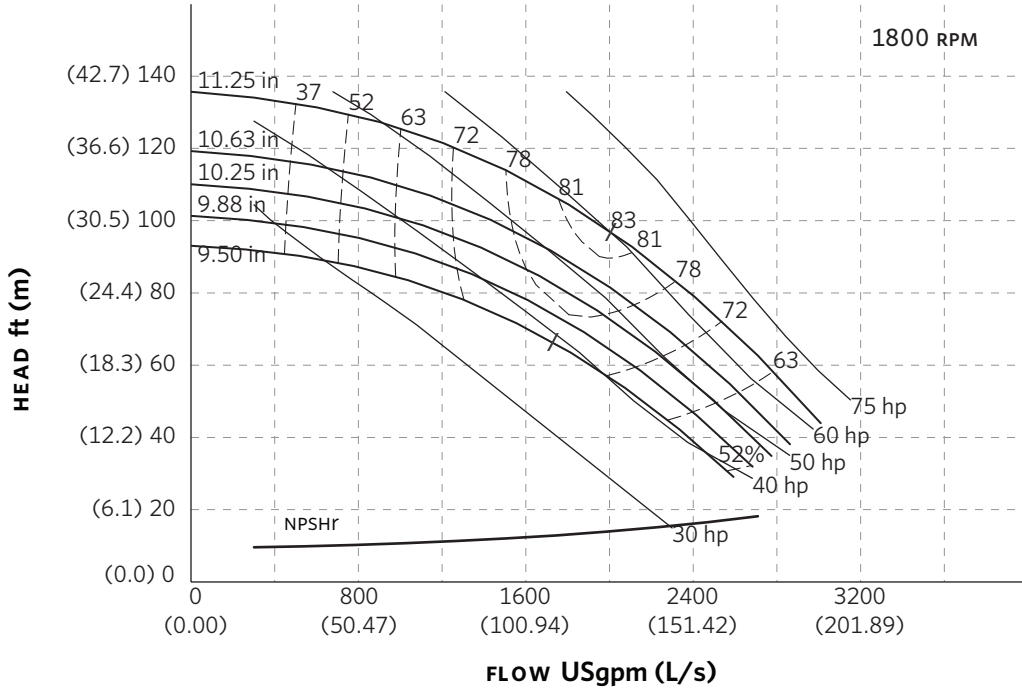

Performance curves are for reference only.
Confirm current performance data with Armstrong ACE Online selection software.

TORONTO

23 BERTRAND AVENUE
TORONTO, ONTARIO
CANADA
M1L 2P3
+1 416 755 2291

BUFFALO

93 EAST AVENUE
NORTH TONAWANDA, NEW YORK
U.S.A.
14120-6594
+1 716 693 8813

BIRMINGHAM

HEYWOOD WHARF, MUCKLOW HILL
HALESOWEN, WEST MIDLANDS
UNITED KINGDOM
B62 8DJ
+44 (0) 8444 145 145

MANCHESTER

WENLOCK WAY
MANCHESTER
UNITED KINGDOM
M12 5JL
+44 (0) 8444 145 145

BANGALORE

#59, FIRST FLOOR, 3RD MAIN
MARGOSA ROAD, MALLESWARAM
BANGALORE, INDIA
560 003
+91 (0) 80 4906 3555

SHANGHAI

NO. 1619 HU HANG ROAD, XI DU TOWNSHIP
FENG XIAN DISTRICT, SHANGHAI
P.R.C.
201401
+86 21 3756 6696

ARMSTRONG FLUID TECHNOLOGY
ESTABLISHED 1934

ARMSTRONGFLUIDTECHNOLOGY.COM

**MAKING
ENERGY
MAKE
SENSE™**